

Operator Controlled Mechanization

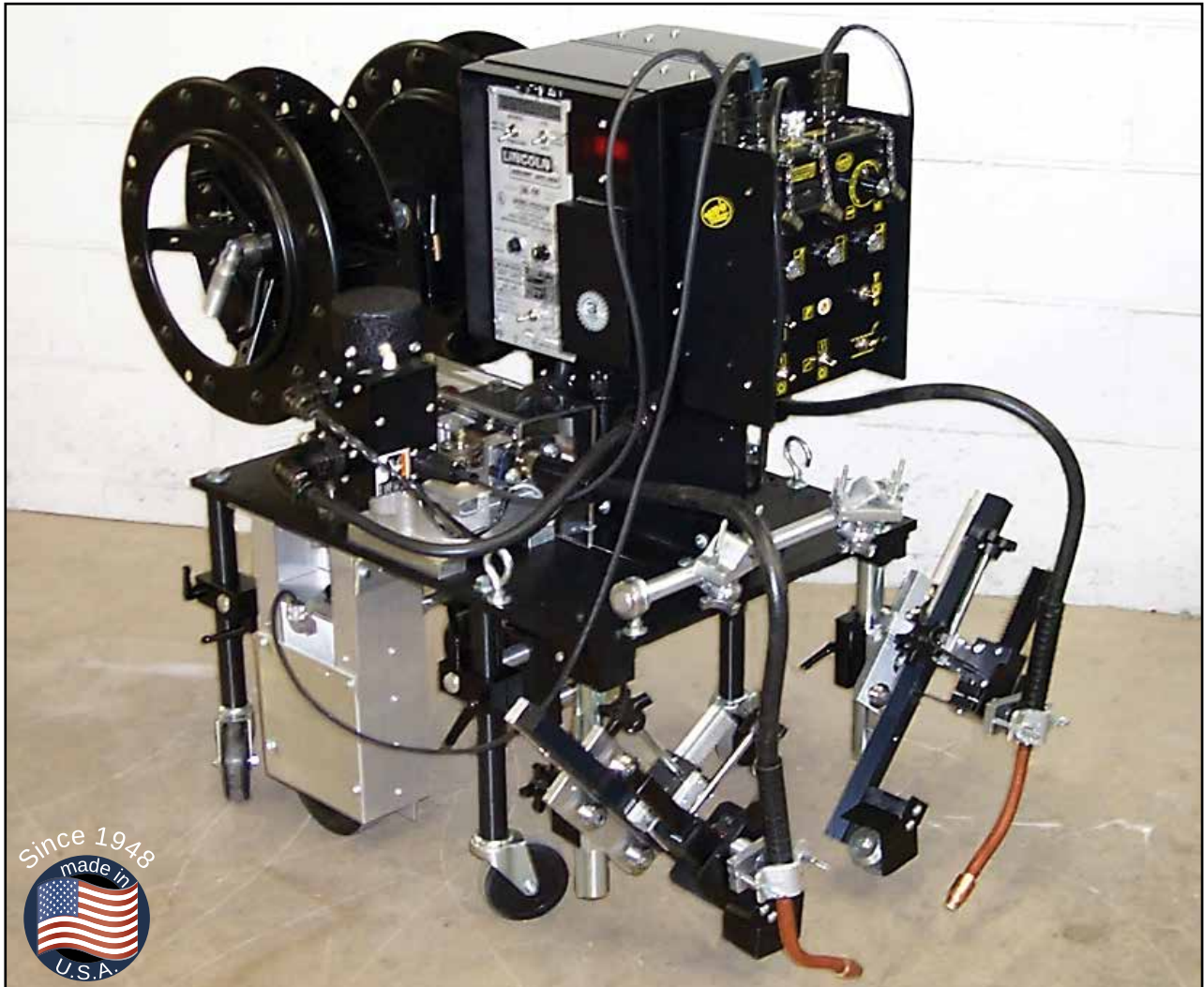

Stiffener Welder with Lincoln Feeders

The Stiffener Welder will weld "I", "T", and "L" stiffeners on one or both sides at the same time.



The **STIFFENER WELDER** from **BUG-O SYSTEMS** is a self-contained, dual head automatic welder. It will produce continuous or intermittent fillet welds on stiffeners with flange widths up to 12" (0-304.8 mm) and heights of 3"-16" (76-406 mm). The unit is self-propelled and tracks on the stiffener. The floating gun holders are spring loaded and have dual wheels to ride over tacks. Three ready to use models are available: FCAW, GMAW and SAW. A bare machine is also available for those who wish to mount their own feeders. *PATENTS WORLDWIDE*

Bug-O Systems is committed to empowering our customers by providing operator controlled mechanized solutions for their welding, cutting and custom applications.

BUG-O SYSTEMS

A DIVISION OF WELD TOOLING CORPORATION



280 TECHNOLOGY DRIVE CANONSBURG, PENNSYLVANIA 15317-9564 USA
PHONE: 412-331-1776 <http://www.bugo.com> FAX: 412-331-0383





STIFFENER WELDER WITH LINCOLN FEEDERS

Operation:

The Stiffener Welder is rolled into position on one end of the beam or stiffener to be welded. The guide wheels are set on each side of the beam to insure that the machine will follow the web of the beam/stiffener as it is being welded. The spring loaded gunholder assemblies are racked into position and the welding guns are centered in the joint to be welded.

All controls for the machine are located on the control panel on the front of the machine. To skip weld, turn the Skip/Continuous switch to the Skip Mode. Set the Skip Length dial to determine how long the machine will travel without welding. Next, set the weld length dial to determine how long the machine will travel while welding. (To do this, make a chalk mark on the work piece and time the machine as it travels). Travel distance is determined by the length of time the dials are set for and the speed the machine is traveling while it welds or skips.

For continuous welding, turn the Skip/Continuous switch to the Continuous position. Then start the machine by turning on the Carriage Travel switch and set the speed of the machine as it welds. A timer is provided for Puddle Buildup and Crater Fill. (See below)

Control Box:

- A. Power Switch
- B. Wire Feed Switches
- C. Skip/Continuous Switch
- D. Carriage Travel Switch
- E. Puddle Buildup and Crater Fill
- F. Skip Length
(The amount of time the machine travels without welding)
- G. Weld Length
(The amount of time the machine welds; skip mode only)
- H. Digital Readout
(of Travel Speed)
- J. Carriage Travel Speed Knob
- K. Power Indicator Light

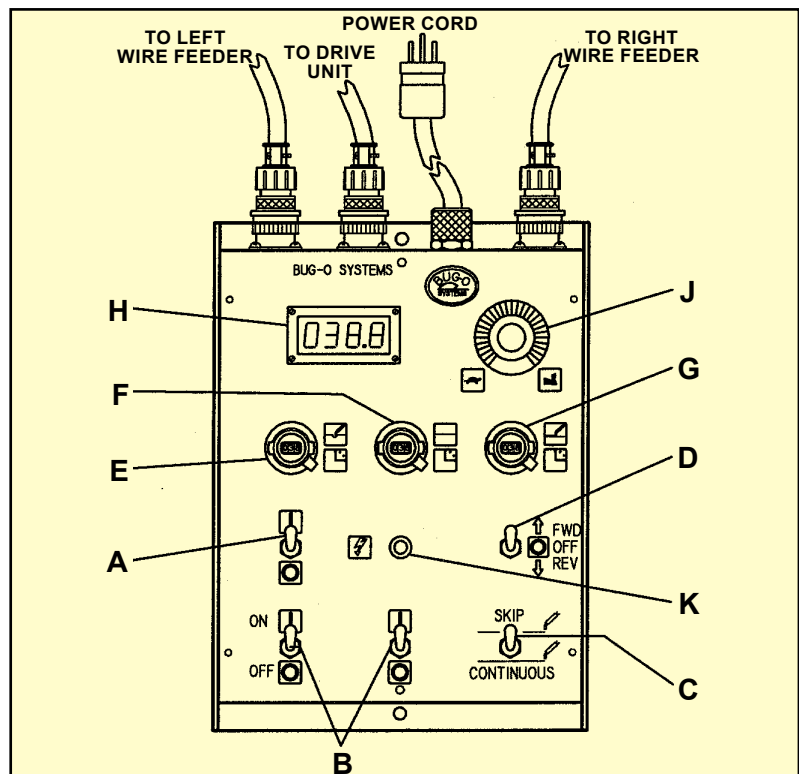

Gunholder Assembly:

The Stiffener Welder has two Spring Loaded Gunholder Assemblies which keep the welding torches aligned while the unit is running. Two "V" wheels ride over tack welds and keep the welding guns centered.

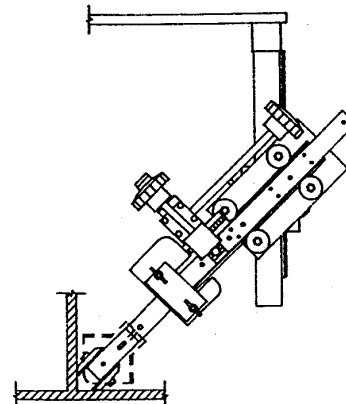



STIFFENER WELDER WITH LINCOLN FEEDERS

Technical Data:

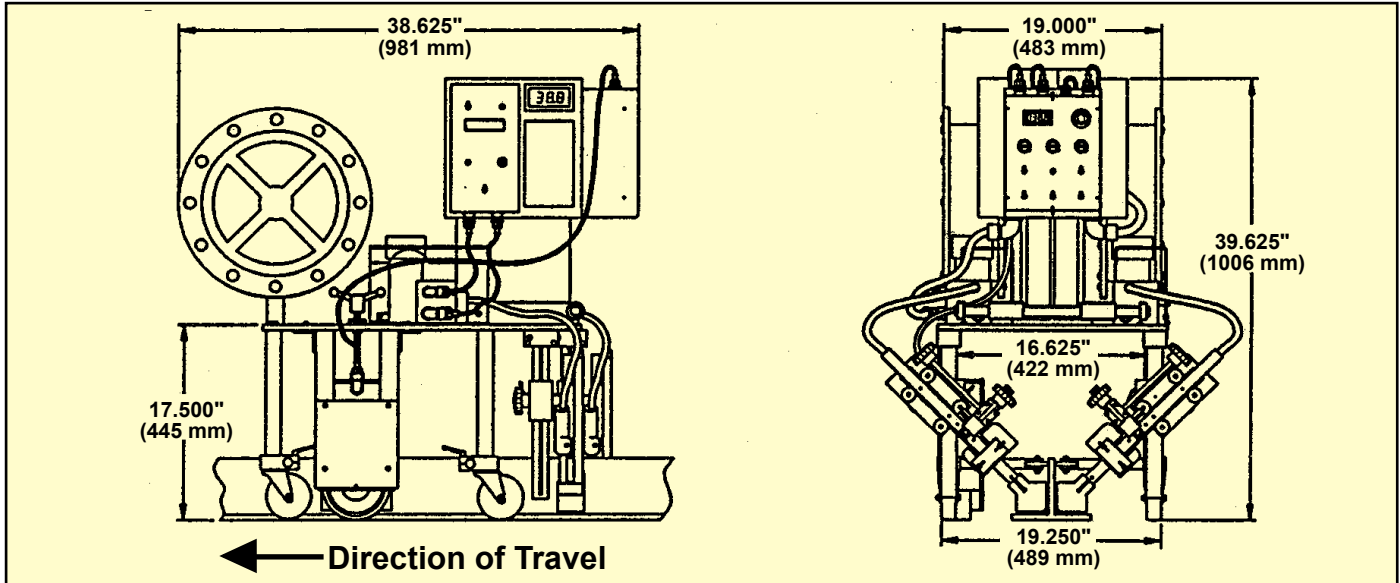

Power Requirement: [Supplied from welding power source]
 80 watts 120/50-60/1
 40 watts 240/50-60/1

Net Weight: 264 lbs. (120 kg) with feeders and reels,
 without welding wire

Travel Speed: 3-44 ipm (7.6-111.7 Cm/min)
 [Digital carriage speed readout- ipm or cm/min]

Controls: Wire feed: manual or automatic [cold wire feed for set up]. Independent control for left and right. Crater travel forward/off/reverse.
 Continuous or intermittent welds:
 Weld length timer: 1-30 seconds
 Skip length timer: 1-30 seconds

BUG-3190 Stiffener Welder Without Feeder 120 VAC Includes:

- 1 BUG-3219 Chain Assembly
- 1 BUG-3220 Carriage Assembly
- 1 BUG-3230 Drive Assembly
- 1 BUG-3240 Drive Support
- 1 BUG-3250 Cable Anchor Assembly
- 1 BUG-3335-L H.D. Corner Follower LH
- 1 BUG-3335-R H.D. Corner Follower RH
- 1 BUG-3270 Spool Bracket
- 1 BUG-3275 Motor/Control Mounting
- 1 BUG-3280 Control Box 120 VAC

Net Weight: 131 lbs. (59.5 kg)
Shipping Weight: 390 lbs. (176.9 kg)

BUG-3192 Same as above except 240 VAC.

- 1 BUG-3282 Control Box 240 VAC

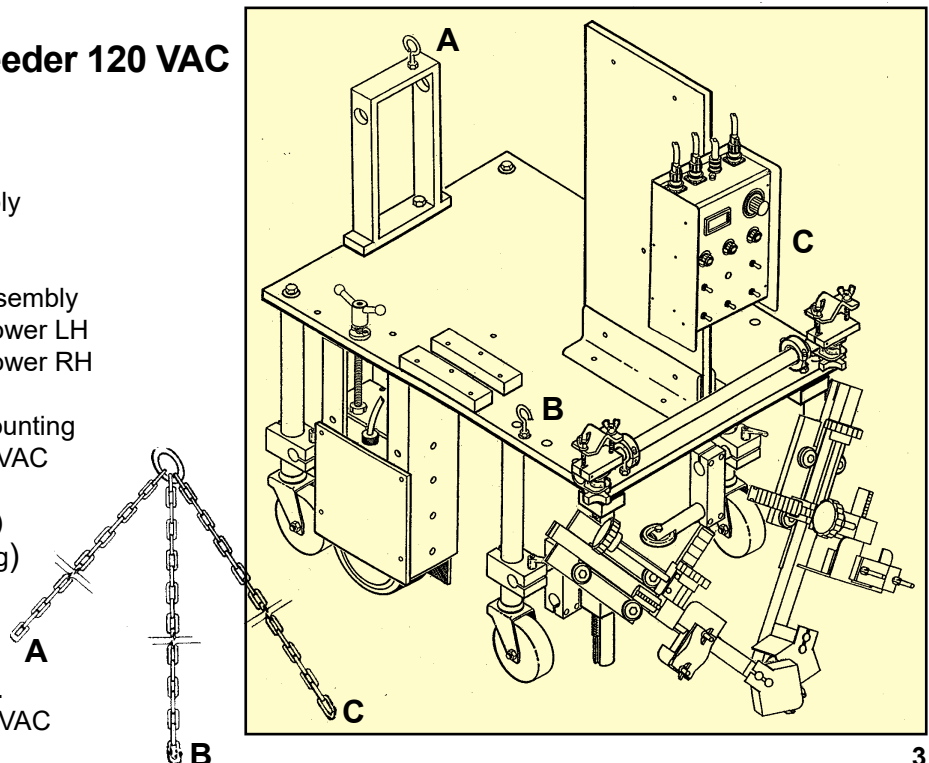



STIFFENER WELDER WITH LINCOLN FEEDERS

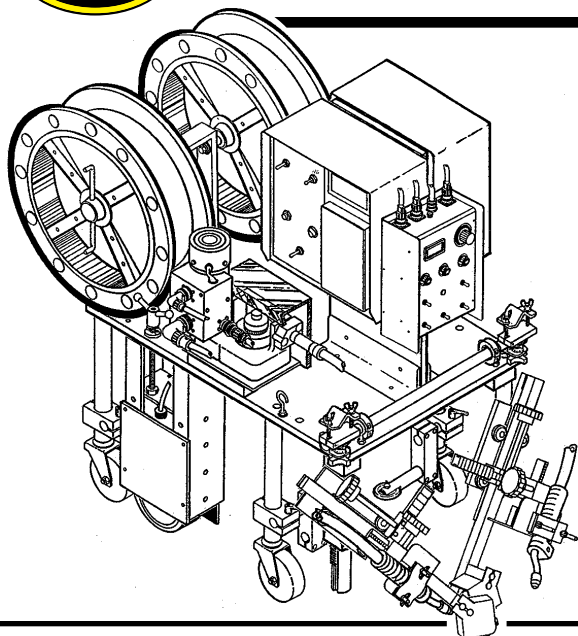

Wire Size *Specify wire size and spool weight when ordering.*
Spool Weight

BUG-3200-XX-XX* Stiffener Welder/Self Shielded Flux Cored Welding 120 VAC/50-60/1

Includes:

- 1 Stiffener Welder with Feeders
- 2 Gun and Cable Assemblies
- 1 Spare Parts Kit
- 2 Reel Assemblies

BUG-3202-XX-XX* Same as above except 240 VAC/50-60/1

Net Weight of Kit: 264 lbs. (120 kg) [without wire]
 Shipping Weight of Kit: 550 lbs. (249.48 kg) [without wire]
 * Wire sizes available: .068, 5/64, 3/32, 7/64, and .120"

BUG-3180-XX-XX* Stiffener Welder/MIG/MAG/Gas Shielded Flux Cored Welding 120 VAC/50-60/1

Includes:

- 1 Stiffener Welder with Feeders
- 2 Gun and Cable Assemblies
- 1 Spare Parts Kit
- 2 Reel Assemblies

BUG-3182-XX-XX* Same as above except 240 VAC/50-60/1

Net Weight of Kit: 270 lbs. (123 kg) [without wire]
 Shipping Weight of Kit: 550 lbs. (249.48 kg) [without wire]
 * Wire sizes available: .035, .045, .052, and 1/16"

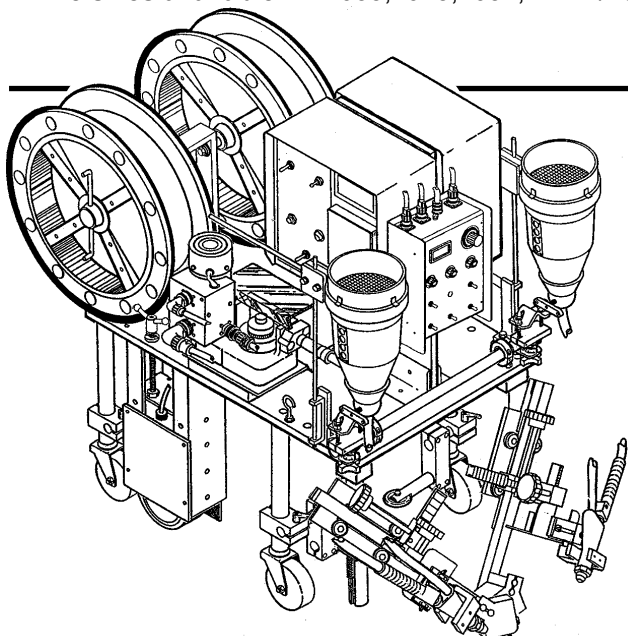
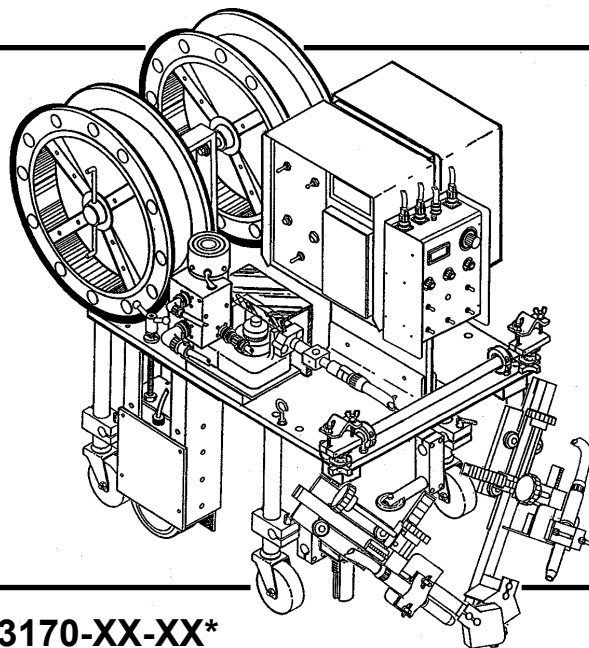

BUG-3170-XX-XX* Stiffener Welder Sub Arc 120 VAC/50-60/1

Includes:

- 1 Stiffener Welder with Feeders
- 2 Gun and Cable Assemblies
- 2 Flux Hoppers
- 2 Nozzle Assemblies
- 1 Spare Parts Kit
- 2 Clamps
- 2 Adaptor Bracket Assemblies
- 2 Reel Assemblies

BUG-3172-XX-XX* Same as above except 240 VAC/50-60/1

Net Weight of Kit: 300 lbs. (136 kg) [without wire]
 Shipping Weight of Kit: 550 lbs. (249.48 kg) [without wire]
 * Wire sizes available: .035, .045, .052, and 1/16"